



TAC MICROZONE II®

Direct Digital Controllers

The TAC NETWORK 8000 MICROZONE II (MZII) is a fully programmable controller that enhances the TAC NETWORK 8000 Facility Management System family offering. The MZII has the ability to employ custom block programs and run them in a stand-alone mode. The MZII block programming language provides the system operator with 100% flexibility for creation of new and unique control strategies.

TAC MICROZONE II is easily applied to a wide variety of mechanical equipment including those that are application specific. Through the Personal System Interface (PSI™) and Xtended Personal System Interface (XPSI™), control programs can be downloaded to all devices requiring the sequence of operation. With the MZII, the TAC NETWORK 8000 provides the best of both worlds; full programmability for easy creation and modification of custom control strategies, and easy duplication of controller databases for mechanical equipment containing similar or identical control strategies.

The MZII utilizes state-of-the-art, surface mount technology which helps reduce the size and cost of the product while providing powerful product features. Modularity of hardware along with the networking capabilities allow easy expandability as the needs of the facility change in the future. As with all other programmable TAC NETWORK 8000 controllers, the MZII utilizes non-volatile EEPROM memory to store application control programs. EEPROM memory allows an owner to modify existing control sequences or create new ones through the Personal System Interface (PSI).

Communications

Ports

RS-485 asynchronous at 19,200 baud (adjustable) to global controller. Modular jack provided for local connection of the Personal System Interface.

Local Terminal (PSI)

PSI can monitor all device parameters and has access to all program blocks and attributes for complete program editing and creation. Provides up/download capability for system maintenance.

Network Device Access

PSI connected at one device has access to all network-wide devices on an ASD communication bus. Connection of PSI will not disrupt the network communications between the MZII controller and other devices on the bus.

TAC NETWORK 8000

Up to 128 MZIIs per Global Control Module. Shared network data includes all physical input/output points plus capability of WINDO and EMS blocks which are program definable.

- Complete user creation of custom control strategies through block programming structure adapts MZII to virtually any HVAC control sequence or mechanical system.
- Models with battery backed-up time clock provide true stand-alone direct digital control with optimum start stop, scheduling functions, and battery backed-up random access memory (RAM).
- Input/output auto trending with adjustable sample rates continually accumulate and time stamp last 48 analog values and last 10 digital changes of state.
- Satellite point command capability from global controllers eliminates "waste" of unused points.
- "Fast" half (0.5) second input to output response times make MZII directly applicable to static pressure, fume hood and laboratory pressurization applications.

Table-1 Model Chart.

Model	Description	Battery Backed-up Time Clock
MZ2A-101	Controller card only	No
MZ2A-102		Yes

SOFTWARE SPECIFICATIONS

Control Functions

Refer to Table-2.

Table-2 TAC MICROZONE II Block Library.

Type	Description
<ul style="list-style-type: none"> • AO • DO • EMS • HOLI • LOOP • OSS • RESET • RGRP • SCHED • SEQ • UI • UTIL 	Analog Output Digital Output GCM™ Input Holiday Schedule Complex PID Loops Optimum Start/Stop Setpoint Reset Receive Global Group Data Weekly/Daily Schedule Linear/Binary Sequencer Universal Input Utility: Counter, Drive, Flow Detect, Limit, Logic, Math, Stop/Start, Process Alarm, Switch, High/Low, Pulse Width Modulation, Thermostat, Status, Timer Window Output to GCM
<ul style="list-style-type: none"> • WINDO 	Window Output to GCM

Accessories

AD-8969-101	10 k ohm shunt resistor kit for high speed count input
AD-8969-202	250 ohm shunt resistor kit for 4 to 20 mA analog input
AD-8969-206	11 k ohm shunt resistor kit for 10 k thermistor sensor (non-850 series)
AD-8961-220	Voltage divider (converts 1 to 11 Vdc signal to 0.5 to 5 Vdc signal)
AE-690	Accessory outboard gear panel 10-7/8 H x 8-1/2 W x 4-1/4 D in. (276 x 216 x 108 mm) for direct nipple connection to MZ2-1E and MZ2-1CE
ENCL-MZ800-PAN	Enclosure, panel mount 10-5/8 H x 8-1/2 W x 4-1/8 D in. (270 x 216 x 105)
ENCL-MZ800-WAL	Enclosure, wall mount 10-7/8 H x 8-1/2 W x 4-1/4 D in. (276 x 216 x 108 mm)
LAPT-80800-PSI	TAC Personal System Interface software (see F-24317)
LAPT-80800-EPS-I	Xtended TAC Personal System Interface software (see F-24317)

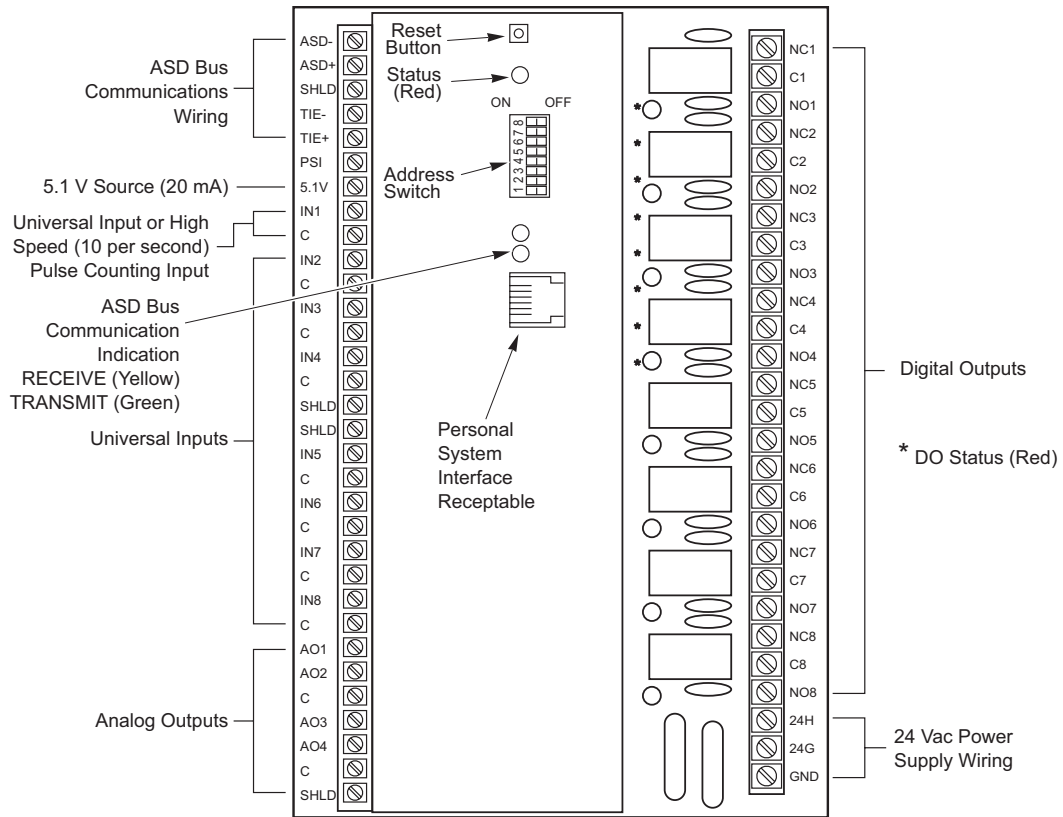
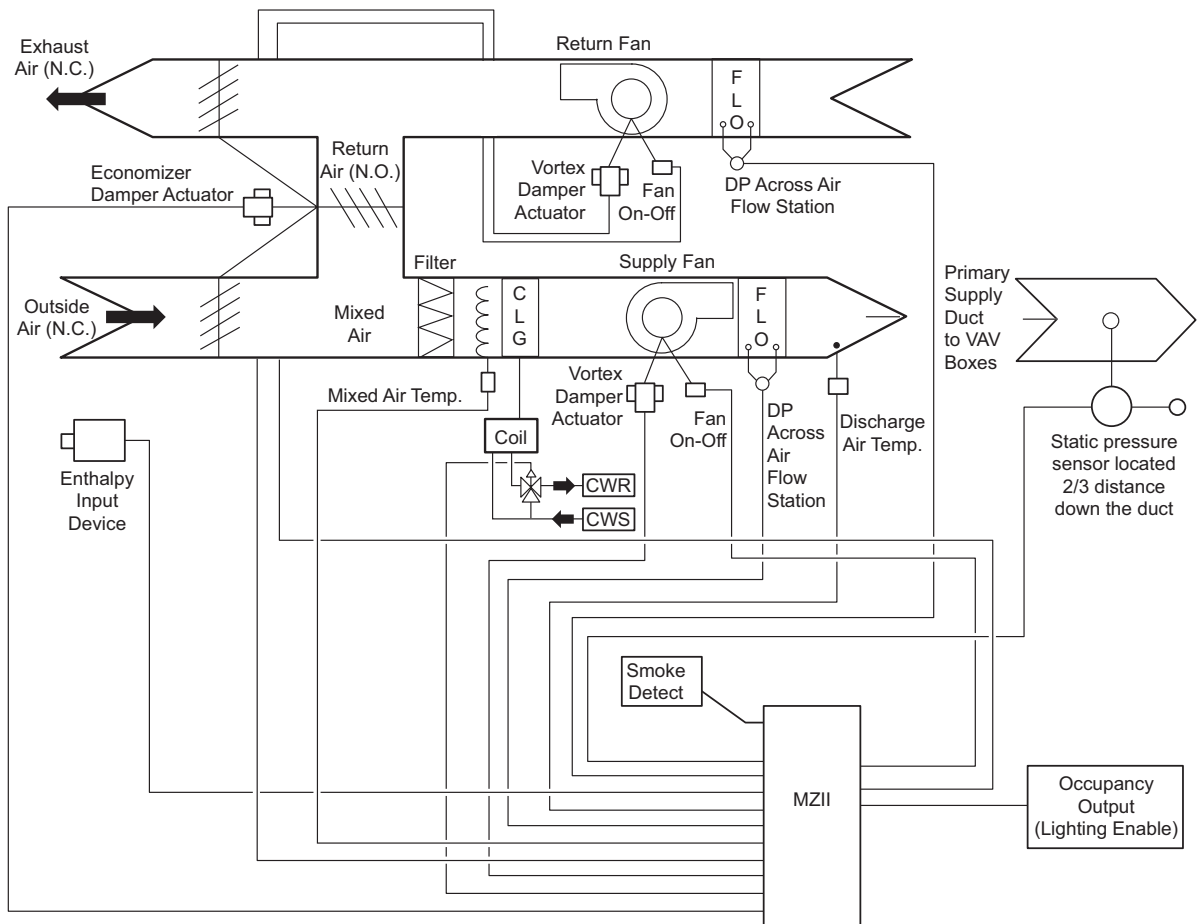

Figure-1 Terminal Connections and LED Indicators.



Note: All field wiring shall be twisted, shielded pairs.

Figure-2 MZII Control Schematic of a Typical Fan Tracking VAV Air Handling System.

SPECIFICATIONS

MF2 SERIES

HARDWARE SPECIFICATIONS

Enclosure

Conforms to NEMA-1. UL-916 rated.

Power Supply Input

20.4 to 30.0 Vac, 50/60 Hz.

Maximum Power Consumption

20 VA at 50/60 Hz.

Transient Compliance Tests

ANSI C62.41 (IEEE 587), Categories A and B.

Electrostatic Discharge Test

±15 kV to case, ±5 kV to field wiring terminals.

AMBIENT LIMITS

Operating Temperature

UUKL Smoke Control

77 °F (25 °C) nominal.

PAZX Energy Management

-40 to 140 °F (-40 to 60 °C).

Shipping and Storage Temperature

-40 to 140 °F (-40 to 60 °C).

Humidity

5 to 95% RH, non-condensing.

Microprocessor

80C198, 7 MHz clock speed, 16-bit word size.

Memory

64 KB of EPROM, 2 KB of EEPROM, 8 KB of RAM.

Wiring Terminals

See Figure-1.

Battery Backup - Clock and RAM

30 days (replaceable lithium battery).

Battery Backed-up Time Clock

Accuracy ±150 sec./mo at 77 °F (25 °C).

Analog To Digital Conversion Resolution

10 bit.

Digital To Analog Conversion Resolution

10 bit.

Input to Output Response Time

0.5 seconds maximum.

UNIVERSAL INPUTS

Quantity

8.

Thermistor Input

20 to 140 °F (-6.67 to 60 °C) range.
TAC Barber-Colman TS-5700-850 series or equivalent.

Balco Input

-40 to 250 °F (-40 to 121 °C) range.
TAC Barber-Colman TS-8000 series or equivalent.

Copper Input

-31 to 240 °F (-35 to 116 °C) range.
TAC Barber-Colman TS-5600 series or equivalent.

Platinum Input

-40 to 240 °F (-40 to 116 °C) range.
TAC Barber-Colman TS-5800 series or equivalent.

Potentiometers

1000 to 20,000 ohm resistance.

Voltage

0 to 5 Vdc.

Current

4 to 20 mAdc with 250 ohm shunt resistor.

Contact Input

Dry.

Maximum Pulse Count Rate

10 per second (50 msec. minimum On or Off time per pulse) to 1 per 4 minutes (1 input per MZII).

1 per second (0.5 sec. minimum On or Off time per pulse) to 1 per minute (up to 7 inputs per MZII).

ANALOG OUTPUTS

Quantity:

4.

Type

0 to 20 mA range programmable source into 500 ohm maximum load, momentary short circuit protection.

DIGITAL OUTPUTS

Quantity:

8.

Contact Ratings

30 VA at 24 Vac, pilot duty.

120 VA at 120 Vac, pilot duty.

Contact Type

Form C (SPDT) isolated.

Status Indication

Light emitting diode.

Voltage Reference

5.1 Vdc, 20 mA maximum.

Copyright © 2006, TAC

All brand names, trademarks and registered trademarks are the property of their respective owners. Information contained within this document is subject to change without notice. All rights reserved.

F-24315-6



TAC
1354 Clifford Avenue
PO Box 2940
Loves Park, IL 61132-2940

www.tac.com

